

CAD FILE:

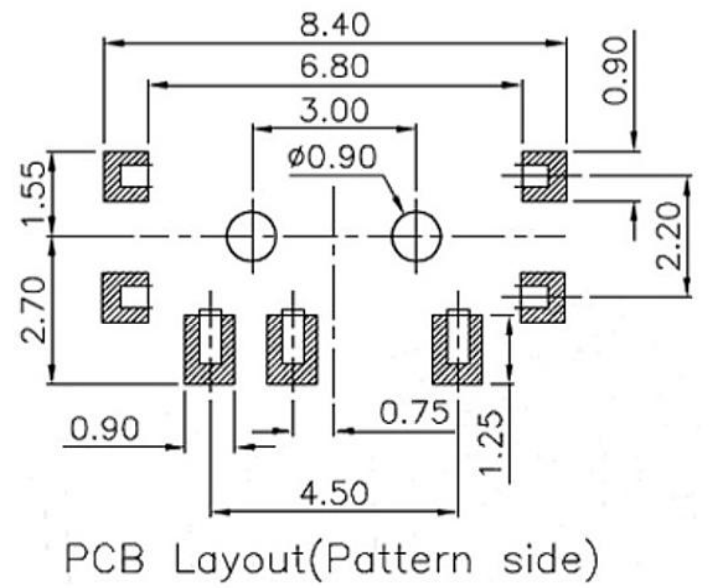
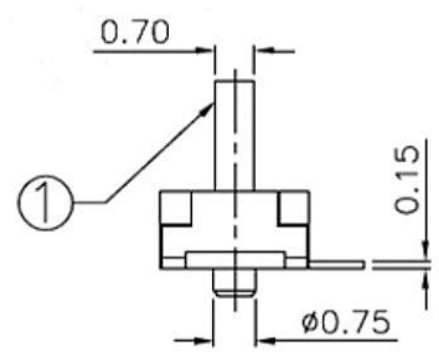
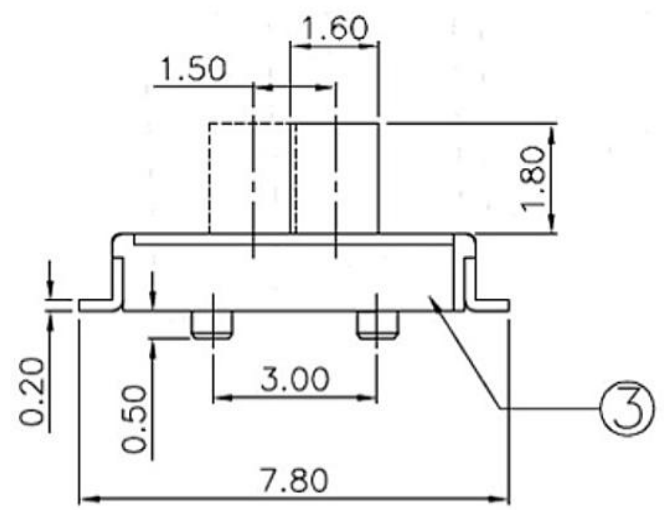
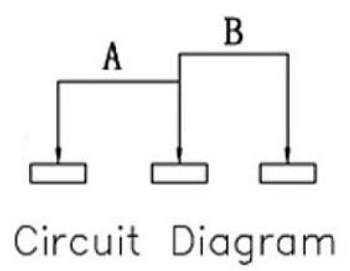
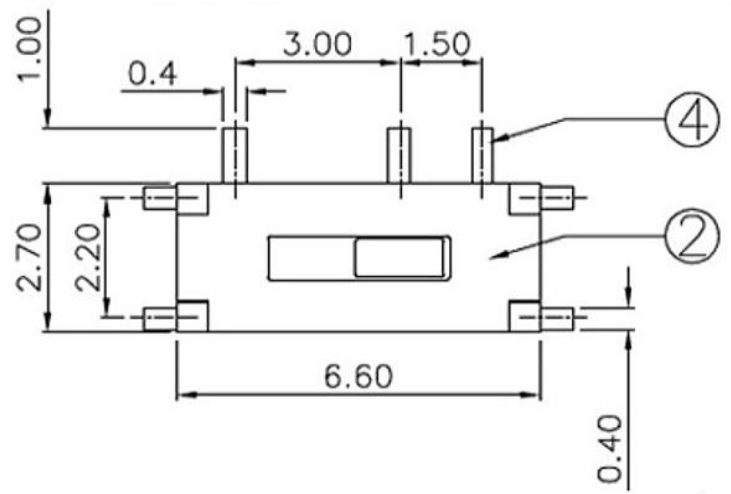

注: "*"表示关键尺寸(6个)

NO.	PARTS	MATERIALS	Q'TY	FINISH	TOLERANCE UNLESS SPECIFIED				DESCRIPTIONS OF REVISION		APPD.
8					WITHIN	A	2012-10-26	初版			
7	STEEL BALL	STEEL	1	NATURAL	OVER	ISSUE	DATE				
6	SPRING	STEEL WIRE	1	NATURAL	TITLE : SLIDE SWITCH				UNIT : mm	DRWG NO.:	
5	CONTACT CLIP	PBS STRIP	2	Ag PLATED	MODEL:				SCALE: 3:1	DWN.	2012-10-26
4	TERMINAL	BRASS STRIP	8	Ag PLATED	東莞市高迪電子有限公司 DONGGUAN GAODI ELECTRONICS CO., LTD.				APPD.		2012-10-26
3	BASE	PHENOLIC RESIN	1	NATURAL					CHK'D		
2	FRAME	STEEL STRIP	1	Ni PLATED					APPD.		2012-10-26
1	KNOB	POM	1	BLACK							